

System - Guided belt measuring system Silent Move WDGMSMN
For heights up to 120 metres (393.70 ft)

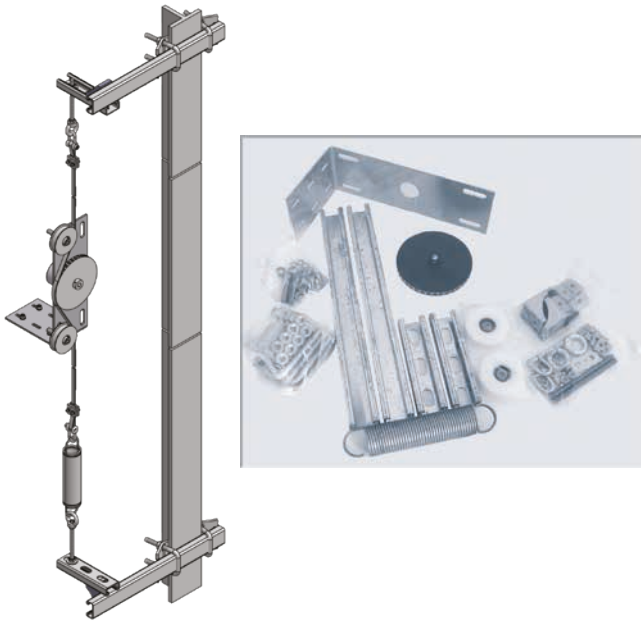

- Measuring set for easy installing the belt on existing brackets in the elevator shaft.
- Quiet and non-slip digital shaft copying for universal mounting on a lift cabin
- Use up to speeds of 4 m/s (800 ft/min).
- Particularly quiet and smooth-running, thanks to special belts and low-noise suspension.
- User-friendly, reliable alternative to switches and sensors.
- Accuracy in the shaft:
 - Incremental encoder WDG158B up to 0.08 mm/pulse (0.0031496 inch/pulse) at 5000 pulses
 - Absolute encoder WDGA58B multiturm, with CANopen interface: 4,096 steps/turn and 262,144 (18 bit multiturm) turns, CANopen LIFT interface: 4,096 steps/turn and 262,144 (18 bit multiturm) turns or SSI interface: 4,096 (12 bit) steps/turn and 8,192 (13 bit multiturm) turns
- Quick and easy mounting with our complete belt fixing and tensioning set.

www.wachendorff-automation.com/silent-move

The quiet **Silent Move** belt landing system devices are systems which are installed quickly and easily in the shaft. All installation components required for standard installation to the lift cab rail or on the wall are supplied.

Noticeably quieter in a noise comparison*:

Conventional System: 92 db
 Silent Move: 68 db

*measured directly at the idler pulley at 4 m/sec (800 ft/min).

Put together your own system for shaft copying, by selecting an encoder and specifying the length of the special belt.



Encoder WDG158B/WDGA58B

Incremental encoders WDG1:

Calculation of resolution in the shaft:

Effective circumference of pulley: 401.11 mm (15.7917322835 inch)

$$\text{Res. in mm (inch)} = \frac{401.11 \text{ mm (15.7917322835 inch)}}{\text{Pulse number of encoder (PPR)}}$$

$$\text{Res. in pulses/mm (inch)} = \frac{\text{Pulse number of encoder (PPR)}}{401.11 \text{ mm (15.7917322835 inch)}}$$

Calculation of the limit frequency:

$$f_g \text{ (Hz)} = \frac{\text{Pulse number of encoder (PPR)} \times \text{max. speed (m/sec) (ft/sec)}}{0.40111 \text{ m (1.3153999 ft)}}$$

Calculation of the traverse path:

$$s \text{ (m) (ft)} = \frac{\text{Pulses (l)}}{\text{Pulse number of encoder (PPR)}} \times 0.40111 \text{ m (1.3153999 ft)}$$

Absolute encoders WDGA:

Repeat precision with WDGA: +/- 0.223 mm (0.00877951 inch)



Self-guiding special belt for exceptionally quiet, non-slip measuring with noise-reducing wheel.

Ordering information - Guided belt landing system WDGMSMN:

Description:	Order No.:
<p>System (without encoder): Belt pulley, 2 tensioning rollers, encoder attachment, attachment of the belt in the shaft, tensioning device for the belt and corresponding assembly components. Please order the special belt separately. (see below: Silent Move special belt, calculation of length)</p>	WDGMSMN
<p>Incremental variants** System with incremental encoder 58B101000ABNM35K3: For an accuracy of measurement of 0.4 mm (0.02 inch) or 2.5 pulses/mm (63.324 pulses/inch) with a limit frequency of 9.972 kHz and a cab speed of 4 m/s (787.4 ft/min). Encoder type 58B101000ABNM35K3: Shaft: Ø 10 mm, pulse number: 1,000 PPR, channels AB and zero pulse + inv. signals, power supply 4.75 VDC up to 30 VDC, channels push-pull, K3: lead outlet 2 m cable, radial</p>	WDGMSMN01000ABNM35K3
<p>System with incremental encoder 58B1025000ABNP24K3: For an accuracy of measurement of 0.016 mm (0.001 inch) or 62.3 pulses/mm (1583.1 pulses/inch) with a limit frequency of 249.3 kHz and a cab speed of 4 m/s (787.4 ft/min). Encoder type 58B1025000ABNP24K3: Shaft: Ø 10 mm, pulse number: 2,5000 PPR, channels AB and zero pulse + inv. signals, power supply 10 VDC up to 30 VDC, channels push-pull, K3: lead outlet 2 m cable, radial</p>	WDGMSMN25000ABNP24K3
<p>Find your incrementalen encoder: With the aid of the calculation forms for limit frequency and resolution in the shaft and the data sheet WDG158B Supply 4.75 VDC to 30 VDC at www.wachendorff-automation.com/wdgi58bm WDG158B supply 10 VDC to 30 VDC at www.wachendorff-automation.com/wdgi58b All variants defined except optional shaft sealed to IP67.</p>	WDGMSMNXXXXXXXXZZK3
<p>Absolute variants WDGA58B CANopen, CANopen LIFT or WDGA58B SSI** System with absolute multiturn encoder with CANopen CiA 406 interface: For an accuracy of measurement of 0.0979 mm (0.0038 inch) or 10.21 steps/mm (259.38 steps/inch). Binary Code: 4,096 (12 bit) steps/revolution and max. 262,144 (18 bit) revolutions. Power supply 10 VDC up to 30 VDC, 5 pin. connector, radial 10 m bus line connector and female connector, T-junction, termination resistor.</p>	WDGMSMN1218COAB00CC5
<p>System with absolute multiturn encoder with CANopen LIFT CiA 417 interface: For an accuracy of measurement of 0.0979 mm (0.0038 inch) or 10.37 steps/mm (259.38 steps/inch), configurable. Binary Code: 4,096 (12 bit) steps/revolution and max. 262,144 (18 bit) revolutions, configurable. Power supply 10 VDC up to 30 VDC, 5 pin. connector, radial 10 m bus line connector and female connector, T-junction, termination resistor.</p>	WDGMSMN1218CLAB00CC5
<p>System with absolute multiturn encoder with synchronous serial interface SSI*: For an accuracy of measurement of 0.0979 mm (0.0038 inch) or 10.21 steps/mm (259.38 steps/inch). * Gray Code (G)/Binary Code (B): 4,096 (12 bit) steps/revolution and 8,192 (13 bit) revolutions. Power supply 10 VDC up to 30 VDC, cable 2 m, radial</p>	WDGMSMN1218SIAX01L3 X = G or B
<p>Comprehensive technical information on WDGA 58B CANopen / WDGA 58B CANopen LIFT / WDGA 58B SSI - www.wachendorff-automation.com/wdga58bcan /wdga58bcanlift /wdga58bssi</p> <p>For encoders with connector always excl. connection cable (exception CANopen & CANopen LIFT systems) Suitable connection cable: KI-9-67-xx-S (incremental), KI-8-67-xx-SSI (SSI) or KI-8-67-xx-EIA (RS485); xx= cable length</p>	
<p>Silent Move special nubbed belt: Calculation of the length: Transport height + 5 m (extend accordingly for transition points) 20 m 35 m 50 m 60 m 80 m 200 m-drum 500 m-drum Special nubbed belt (XXX = figures in metres)</p>	WDGNR020 WDGNR035 WDGNR050 WDGNR060 WDGNR080 WDGNR200 WDGNR500 WDGNRXXX

Customs tariff number: 90318020
Country of origin: Germany